

## DRILLING BED TO FRAME HOLES for 1/2" Bed-to-Frame bolts with Offset Washers

These are suggestions on how to drill and countersink the locations for the bed-to-frame bolts and offset washers that sit on the top of the wood surface. If wood was purchased without holes or you are making your own wood, the following steps will direct you through this process. You should have your bed put together: bed sides, front bed panel, rear cross sills and cross sills, bed wood boards and bed strips. See figure 1.

1. The cross sills are generally the locations for the bed-to-frame mounting bolts. However, There may be instances where a cross sill does not bolt to the frame. Some cross sills may also have multiple hole patterns. Using the mounting locations on the frame as a reference, mark the bottom of the wood boards through the bed-to-frame holes in the cross sills. These marks may be on one board per side of the truck or on two boards for each side. See figure 2.
2. The bed-to-frame bolts near the tailgate do not pass through a cross sill on most trucks. This last pair of bolts pass through large brackets welded to the rear cross sill. See figure 3. It is not possible to mark the boards through these brackets because the hole is oblong on the bottom and the top of the bracket is open. Take a reference measurement from the bed-to-frame hole on the frame just forward from this pair and translate these marks to the boards. In most cases the width of the frame at the rear cross sill will be the same as the cross sill in front of it.
3. Make reference as to which end of each board is at the front of the bed. Remove the bed strips and the boards with the marks. The bottom side of these boards now have 5/8" diameter marks on them. Drill a 1/8" diameter pilot hole through the center of these marks completely through the boards.
4. On the top surface of the boards, measure toward the front of each board 1/4" from each pilot hole and mark the boards for the countersink. See figure 4.
5. Using a 2" Forstner bit and a drill press, countersink each location approximately 1/8" to 5/32" deep. This could be done with a 1/2" hand drill, but is not recommended. See figure 5.

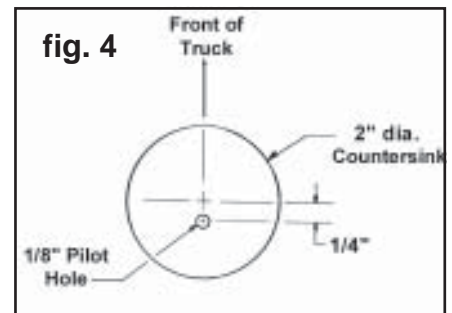

6. From the top surface, drill through the 1/8" pilot holes with a 15/16" wood bit to complete the bed-to-frame holes. See figure 6. Before drilling the 15/16" hole, place a piece of scrap wood directly under the 1/8" hole to prevent splintering as the drill breaks through.

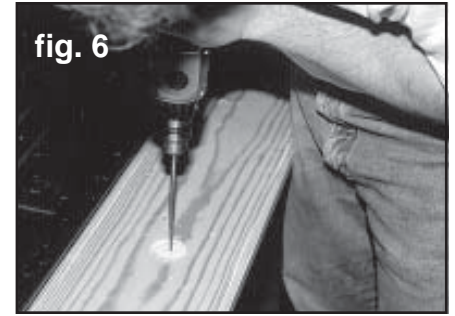

7. Re-install these boards and strips.

8. Align the bed holes to the frame holes. Install the carriage bolts with the offset washer through the wood boards, cross sills/brackets, wood blocks/rubber pads, and the frame. Secure with the flat washers, lockwashers, and nuts.

**PLEASE NOTE:** \*These are **suggestions only**. Please refer to the specific instructions for each year series in the Bed Assembly Instructions for more detailed information.