

## 64-86 FORD STYLESIDE "WELD-IN" TAILGATE PANEL

This tailgate cover fits over the lower indented part of the tailgate to provide a smooth appearance. It must be welded at the top edge and sides. The top edge seam must be ground, filled, and smoothed to blend with the original tailgate contours.

### Suggested Installation Procedure:

1. Remove tailgate from the truck.
2. If installing a louvered cover paint the tailgate flat black in the general area where the louvers will be. If installing a cover with a handle hole, paint the handle and surrounding area the same as the final color of the truck.
3. Position the cover on the tailgate and clamp it in position to verify correct fit. If it has a handle hole check that the handle will still operate with the cover in place. The cover should be clamped at each of its four corners.
  - a. **\*NOTE:** If the handle mechanism is to be repaired or replaced it should be done before the cover is installed.
4. Tack weld the cover first at the two lower corners.
5. Leave all clamps in place and begin welding the top seam. Start welding in the center and place "tack" welds along the top seam about every 4" apart, working toward the outer edges.
6. Again check that the cover is fitting correctly with no wrinkles or bulges.
7. Continue welding the top seam. Small welds about **1/4" or 3/8" long** should be spaced between the tack welds, keeping heat to a minimum and making successive welds in different areas of the tailgate to minimize distortion from welding heat. Work slowly and do not cool the welds with water. Allow each weld to cool naturally before continuing to the next one.
8. Weld the ends of the cover to the tailgate.
9. Tack weld the bottom of the tailgate cover to the tailgate in several places along the seam.
10. Grind the ends of the cover even with the end of the original tailgate. Fill these seams with seam sealer to keep out water.
11. Grind the top seam smooth to blend with the original tailgate contour.
12. Fill the welded seam as necessary with lead or plastic filler. Blend it to the desired contour.
13. The cover is now ready for degreasing, sanding, and final paint finishing.

©Copyright 1997 MAR-K Specialized Mfg. All rights reserved.

Another Outstanding Part Manufactured in Oklahoma City, USA by



# RESTORATION & CUSTOM PICKUP PARTS

## BED STRIPS

## BED WOOD

- Bed Sides
- Tailgates
- Cross Sills
- Rear Sills
- Hardware
- Front Bed Panels

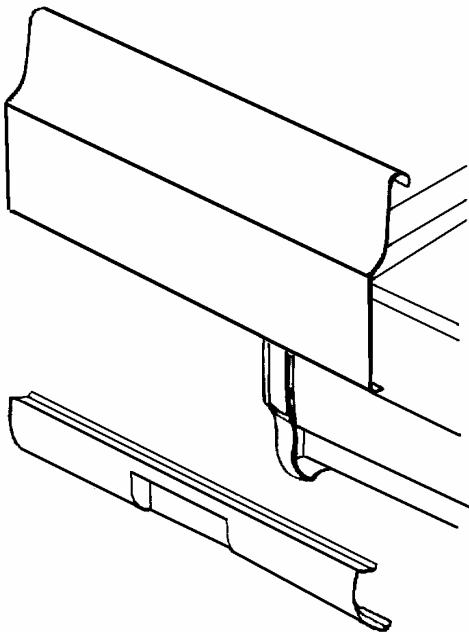
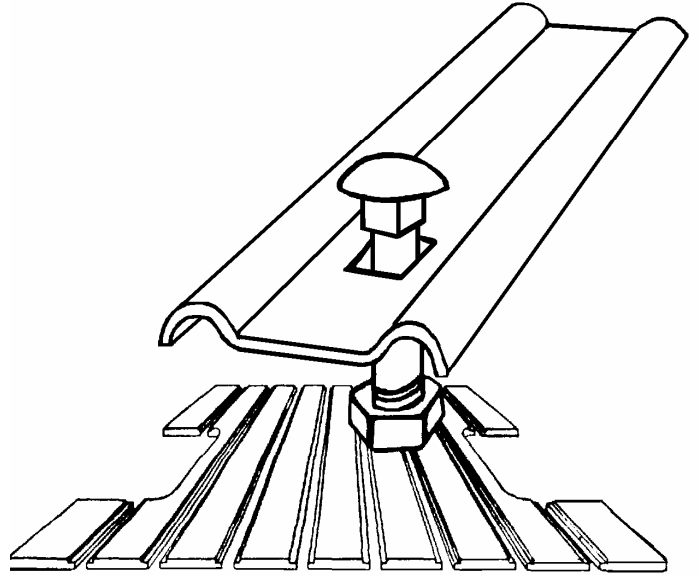

## REAR PANS FRONT PANS TAILGATE COVERS HANDLE KITS

- Weld on or bolt on panels
- Complete instructions included
- 18 Gage steel
- Smooth or Louvres

**\*\* PARTS AVAILABLE VARY EACH STYLE – CALL FOR MORE INFO\*\***