

GM Bed to Frame Mounting Examples

GM 41 - 46 Stepside:

Install the completed bed assembly to the truck frame. This will enable you to check the alignment of the bed-to-frame bolt locations. The order in which parts are installed on the truck frame is: rubber pad, wood mounting block, cross sill bracket/cross sill, and the bed assembly. Install the bed to frame carriage bolts with the offset washer through the wood boards, cross sills/brackets, rubber pads, and the frame. Secure with the 3/8" flat washers, lockwashers, and nuts. See figure 1. The small wood blocks with the offset hole are used under the cross sill that is closest to the rear cross sill. Be sure to install the cross sill brackets with the offset hole on that same cross sill. The large wood blocks are attached to the bedsides near the rear sill for 1/2 ton trucks and are attached to the rear sill for 3/4 ton trucks.

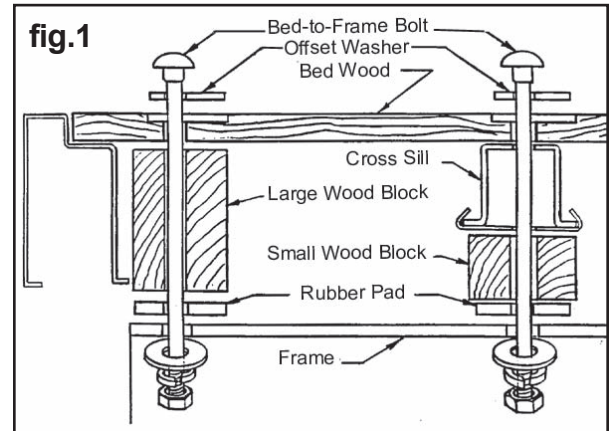

41-46 GM

GM 47 - 53 Stepside:

Install the completed bed assembly to the truck frame. This will enable you to check the alignment of the bed-to-frame bolt locations. The order in which parts are installed on the truck frame is: rubber pad, wood mounting block, cross sill bracket/cross sill, and the bed assembly. Install the bed to frame carriage bolts with the offset washer through the wood boards, cross sills/brackets, rubber pads, and the frame. Secure with the 3/8" flat washers, lockwashers, and nuts. See figure 2. The wood mounting blocks with the offset hole are used under the cross sill that is closest to the rear cross sill. Be sure to install the cross sill brackets with the offset hole on that same cross sill. The 12 inch long bed to frame bolts go in the bed to frame locations that are closest to the cab. All remaining bed to frame bolts are 6" long.

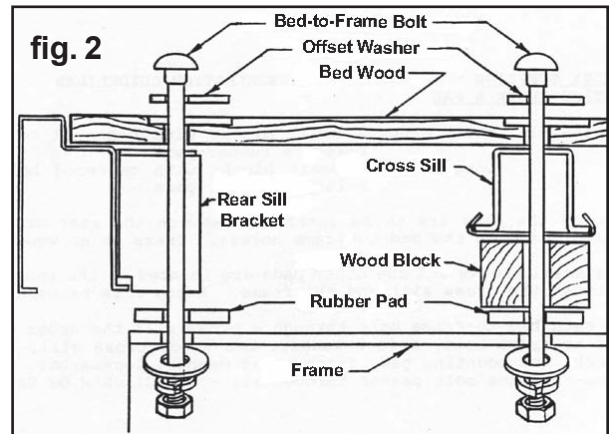

47-53 GM

GM 54-87 Stepside

Install the completed bed assembly to the truck frame. This will enable you to check the alignment of the bed-to-frame bolt locations. There should be a rubber pad between each cross sill bracket and frame mounting location. Align the bed wood mounting holes to the bolt holes in the frame. Install the bed to frame carriage bolts with the offset washer through the wood boards, cross sills/brackets, rubber pads, and the frame. See figure 3. There are several sizes and styles of these parts so your model may not look exactly like the picture. Secure the bed to frame bolts with flat washers, lockwashers, and nuts.

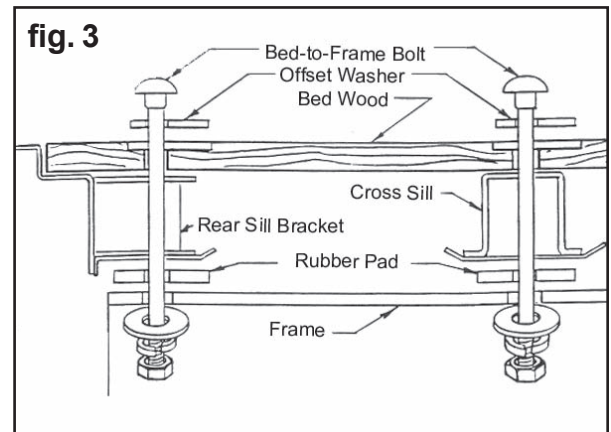

54-87 GM

PLEASE NOTE: *These are **suggestions only**. Please refer to the specific instructions for each year series in the Bed Assembly Instructions for more detailed information.



FORD Bed to Frame Mounting Examples

Ford 51-52:

Install the completed bed assembly to the truck frame. This will enable you to check for correct alignment at the bed-to-frame bolt locations. The center cross sills have a bracket welded for support at the bed to frame bolt location. You may wish to use a rubber pad between all mounting points of the frame and bed assembly as shown in figure 4. After checking the alignment of the bed assembly to the cab and frame mounting holes, install the bed-to-frame bolts through the bed wood mounting holes, cross sills and into the frame holes. There will be six flat head or oval head bolts with the special washers that are recessed about 1/8" in the wood boards. See figure 4. Install the flat washers, lock washers, and nuts on the bottom side. The rear sill brackets bolt directly to the frame under the wood surface. Use two standard 7/16 hex head bolts for this location. Rear sill mounting bolts are not provided in our floor kit.

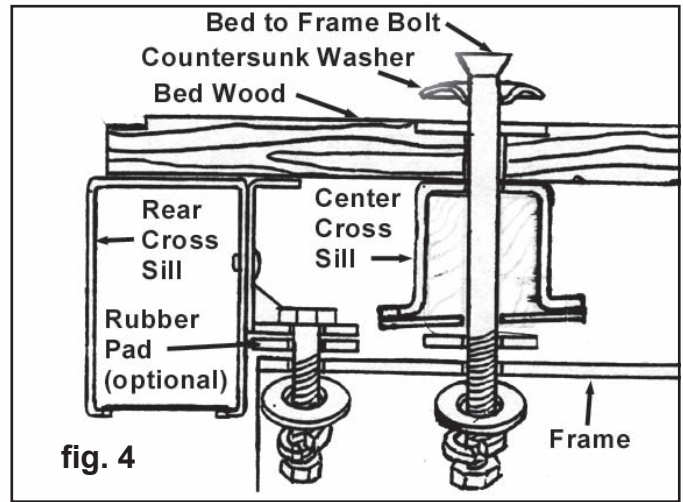

51-60 Ford

Ford 53-60:

Install the completed bed assembly to the truck frame. This will enable you to check the alignment of the bed-to-frame bolt locations. The center cross sills have a bracket welded for support at the bed to frame bolt location. You may wish to use a rubber pad between all mounting points of the frame and bed assembly as shown in figure 4. After checking the alignment of the bed assembly to the cab and frame mounting holes, install the bed-to-frame bolts. There will be two "dome head" bolts through the bed strips near the bedsides at the front and four flat head or oval head bolts near the center area of the bed with the special washers that sit recessed in the wood boards. See figure 4. Install the flat washers, lock washers, and nuts on the bottom side. The rear sill brackets bolt directly to the frame under the wood surface. Use two standard 7/16 hex head bolts for this location. These rear sill mounting bolts are not provided in our floor kit.

Ford 61-72:

Install the completed bed assembly to the truck frame. This will enable you to check for correct alignment at the bed-to-frame bolt locations. Place the bed mounting blocks inside the two center cross sills over the frame hole locations. The hole in the wood block will line up with the holes in the cross sill, bed wood, and frame. You may wish to use a rubber pad between all mounting points of the frame and bed assembly as shown in figure 5. After checking the alignment of the bed assembly to the cab and frame mounting holes, install the bed-to-frame bolts through the bed wood mounting holes, cross sills, wood blocks and into the frame holes. There will be six flat head or oval head bolts with the special washers that are recessed about 1/8" in the wood boards. See figure 5. Install the flat washers, lock washers, and nuts on the bottom side. The rear sill brackets bolt directly to the frame under the wood surface. Use two standard 7/16 hex head bolts for this location. These rear sill mounting bolts are not provided in our floor kit.

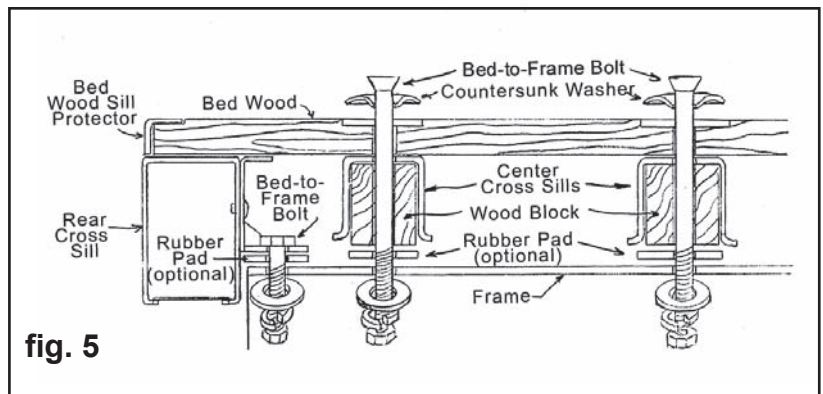

61-72 Ford

PLEASE NOTE: *These are **suggestions only**. Please refer to the specific instructions for each year series in the Bed Assembly Instructions for more detailed information.