

# MAR-K

RESTORATION AND CUSTOM PICKUP PARTS

## BED PARTS ASSEMBLY GUIDE 73-87 GM SHORT STEPSIDE

If you have not yet disassembled your original bed, make notes or sketches and take pictures of part locations to aid in the assembly procedure. Use the following steps to assemble the entire bed to test fit all parts.

1. Begin with one bed side and the front bed panel. Bolt these together using (5) 5/16"-18 x 3/4" indented hex head screws, (3) lock washers, and (3) nuts. (Two of these bolts thread into a plate welded into the curl area of the front bed panel.) See figure 1.
2. Bolt the front bed panel to the other bed side with (5) 5/16"-18 x 3/4" indented hex head screws, (3) lock washers, and (3) nuts.
3. Fit the rear cross sill inside the lower portion of the bed side rear stake pockets with the open side of the rear cross sill facing downward. See figure 2. The large mounting brackets should be facing toward the front bed panel. See figure 3.
4. Using (10) 5/16"-18 x 3/4" indented hex head screws, lock washers, and nuts, bolt the rear cross sill to the stake pockets. See figure 3.
5. Once these four pieces of the bed are assembled, make sure the bed is square. Measure the bed width at the top and bottom of bed sides to ensure that the bed sides are straight up and down and are 50" apart. See figure 4. Tighten the rear cross sill bolts.

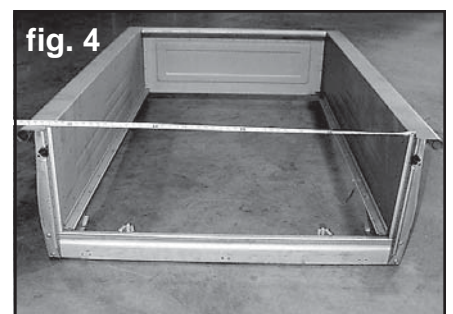
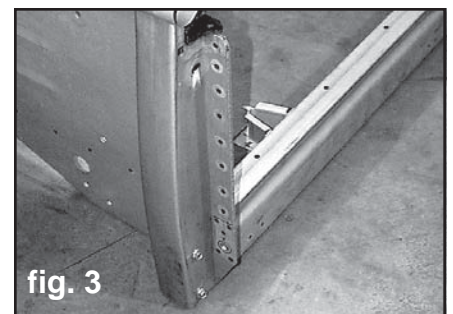
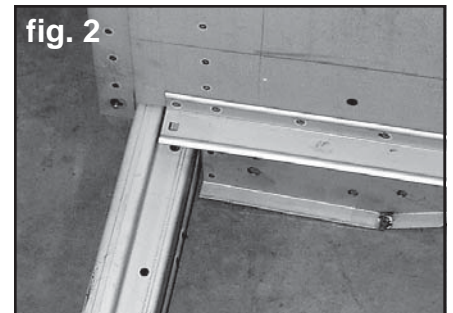
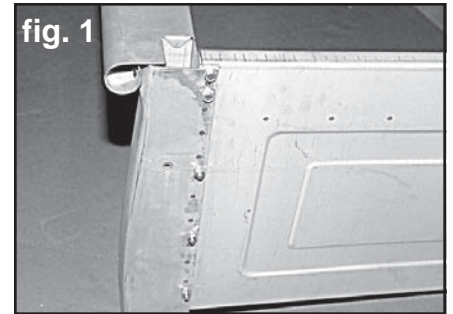

6. Measure crosswise from the front of the bed to opposite rear of the bed on both sides. These measurements should be within 1/16" of each other to ensure your bed is square. Now tighten all bolts. See figure 5.
7. Place the assembly on supports horizontally to gain access to both the top and bottom of the bed floor area. This can also be achieved by standing the bed assembly vertical. Place a blanket or other protection on the floor and stand the bed assembly on the front bed panel.

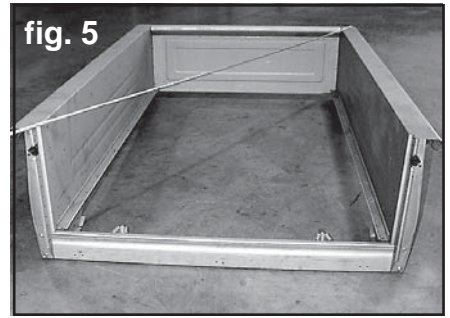

**Note:** The original 73-87 GM bed sides had the angle strip bolts welded to the angle strip. If using replacement angle strips or if the angle strip bolts or rear sill have been removed from the bed sides follow **version 1** of steps #8 through #11. If the original angle strip bolts remain in place and are in good condition, follow **version 2**. If the bolts are not in good condition, they will need to be removed. Center punch the heads of the bolts. Drill through each bolt head approximately 1/4" deep with a 1/8" drill. Keep stepping up drill sizes until the threaded portion of the bolt is separated from the head. Grind the heads of the bolts from the angle strip being careful not to grind the angle strip itself. You may also use an air chisel to remove the bolt head from the angle. Work cautiously and flatten and dress all areas when finished. Now follow **version 1**.

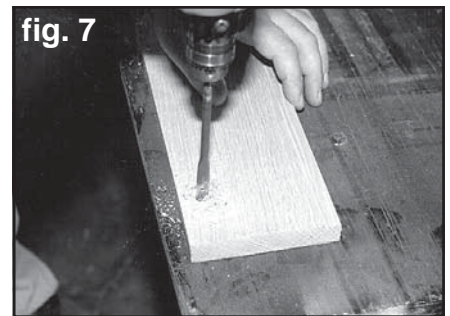

#### **Version 1: Bolts removed**

8. Place the wood boards that have only one bed strip groove (referred to as "edge boards") under the angle strips on the bedsides. The non-grooved edge should be toward the bedside. Leave approximately a 1/16" gap between bedside and the board.
9. Mark all holes to be drilled in the edge boards through the angle strips holes. See figure 6.
10. Remove these two edge boards and drill all holes marked with a 3/8" wood bit. Be careful not to splinter the other side of the board when drilling. Placing a scrap block of wood behind the boards where drilling will help prevent this. See figure 7.
11. Install the edge boards under angle strips as in step #8. Place 5/16"-18 x 1-1/2" carriage bolts through the angle strips and through the wood boards. Leave off the lock washers and nuts for now. See figure 8.



**Version 2:** Using original bolts welded to angles

8. Select the two boards that have only one bedstrip groove. These edge boards will be drilled to align with the angle strip bolts. The non-grooved edge will be toward the bed side under the angle strip.
9. Measure from the front of the angle strip to the center of each angle strip bolt. Transfer these measurements to the non-grooved edge of the boards selected in step 8. Be sure to make a right hand and left hand board.
10. Drill a 3/8" diameter hole 11/16 from the edge at each bolt location as marked in step 9. If rear sill is not welded to the stake pockets, skip to step 12.
11. The holes drilled in step 10 need to be slotted to the edge of the board. This allows the board to be slid under the angle strip and around the angle strip bolts without removing the rear sill and front bed panel. Use a jigsaw to saw 3/8" wide slots at the bolt locations as shown in figure 9.
12. Install the edge boards under the angle strips. If step 11 was skipped, the rear sill and front panel will need to be separated from the bed side temporarily to install the edge boards.

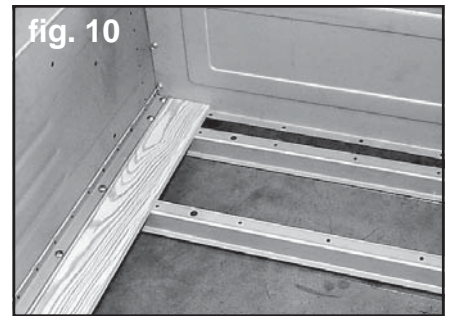
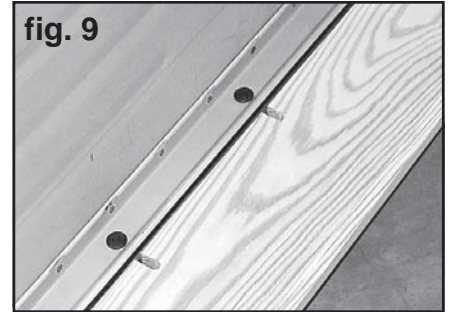

**Both versions resume:**

13. Attach the cross sills to the 5/16" angle strip bolts that are approximately **3-5/8"**, **14-1/8"** and **64-1/2"** from the front bed panel. See figure 10. Secure with lock washer and nut hand tight. The cross sills should be installed so that when the bed is on the frame the cross sills will be open toward the ground.
14. There are two other sills that are similar in appearance to the cross sills only smaller. These reinforcement strips attach angle strip bolts approximately **22-1/8"** and **58"** from the front bed panel. Install lock washer and nut hand tight.
15. Place the next board into position on both the left and right sides leaving approximately a 1/2" gap between the boards.



16. Install a bed strip between these boards. See figure 11. The front of the bed strip is the end with the two holes closest together. The second, third, and eighth bed strip holes should line up with the cross sills. The fourth and seventh bed strip holes should line up with the reinforcement strips. The ends of the bed strip bolt to the front bed panel and the rear cross sill. *If using MAR-K's custom bed strips with hidden fasteners, follow the instructions supplied with the bed strips for correct installation.*

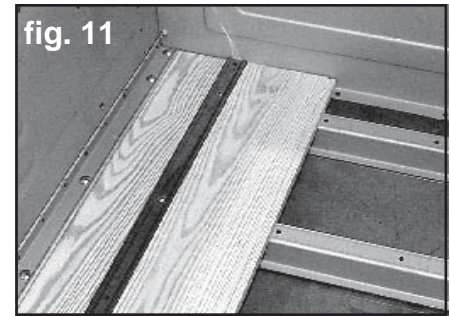

17. Loosely install the 1/4"-20 x 1-1/4" carriage bolts, lock washers, and nuts through the bed strips into the cross sills, reinforcement strips, and rear cross sill. **The front of the bed strip uses a 5/16"-18 x 1-1/2" carriage bolt instead of the 1/4" bolt.** This bolts to the front bed panel.



**Note:** The next step is to drill and countersink the locations for the bed-to-frame bolts and offset washers that sit on top of the wood surface. If wood is purchased with the frame holes predrilled, skip to step #28. If wood is purchased without holes, the following steps will direct you through this process.

18. The first cross sill back from the front of the bed is the first bed-to-frame location. Mark the bottom of the wood boards through the 5/8" diameter holes in the sill that are **31-3/4"** apart from center of hole to center of the other hole. See figure 12.

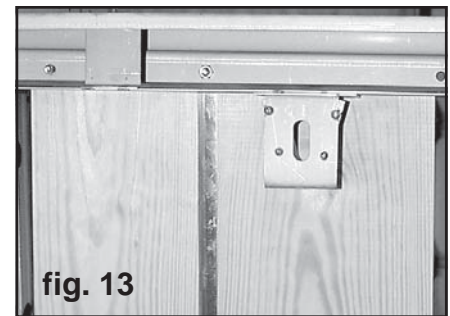

19. The second cross sill back is the next bed-to-frame bolt location. Mark the bottom of the boards through the 5/8" diameter holes in the cross sill that are **31-3/4"** apart.
20. The third cross sill back is the third bed-to-frame bolt location. Mark the bottom of the wood boards through the 5/8" diameter holes in the cross sill that are **31-3/4"** apart.
21. The last bed-to-frame bolt location near the tailgate does not pass through a cross sill. There are two large brackets welded to the rear cross sill. The wood rests on these brackets and the bed-to-frame bolt passes through the brackets. See figure 13.
22. Mark the bottom of the wood boards through these brackets. The spacing of these large brackets should be **31-3/4"** apart center to center. These marks should be **74-5/8"** back from the front of the wood.
23. Make reference as to which end of each wood board is the front. Remove these two inner boards and bed strips. The bottom side of these boards now have (4) 5/8" diameter marks on each of them. Drill a 1/8" diameter pilot hole through the center of these marks completely through the boards.

24. On the top surface of the boards, measure toward the front of each board 1/4" from each pilot hole and mark the boards for the center of the countersink. See figure 14.

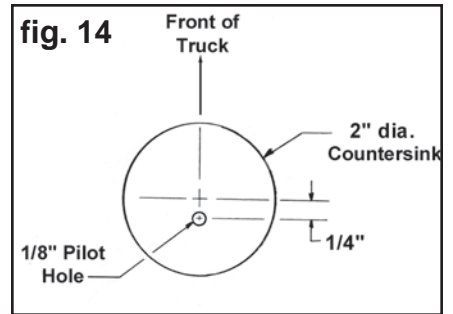

25. Using a 2" Forstner bit and a drill press, countersink each location approximately 1/8" to 5/32" deep. This could be done with a 1/2" hand drill, but is not recommended. See figure 15.

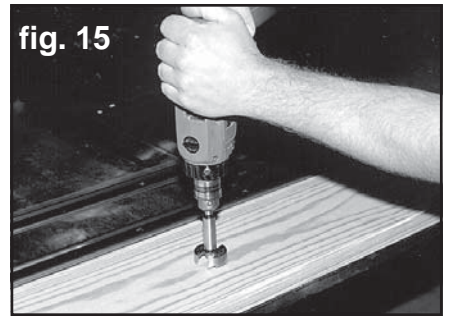

26. From the top surface, drill through the 1/8" pilot hole with a 15/16" wood bit to complete the bed-to-frame holes. See figure 16.

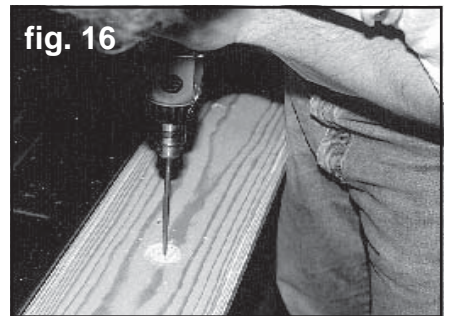

27. Reinstall these two boards and strips. Make sure the bed-to-frame spacing measurements are the same as in steps #17, #18, #19, and #21.

28. Clamp the cross sill brackets to the bottom legs of the cross sills. Align the brackets to the bed-to-frame holes drilled through the boards. Protect wood boards from welding burns and tack weld the brackets in place. See figure 17.

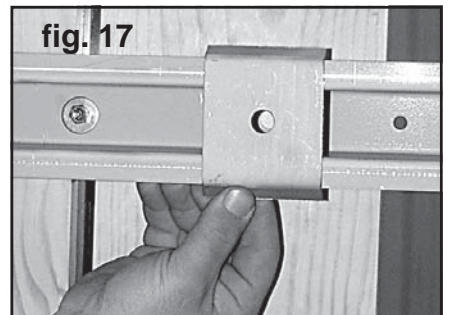

29. Where there is not a cross sill or reinforcement strip attached to the angle strip bolts, install a 1-1/2" outside diameter washer with a 5/16" diameter hole on the bottom of the wood surface before installing lock washer and nut. See figure 18.

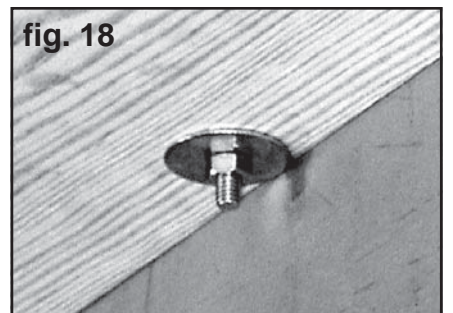

30. Where there is not a cross sill or reinforcement strip under the bed strip bolts, install a 1-1/2" outside diameter washer with a 1/4" diameter hole before installing lock washer and nut. See figure 19.

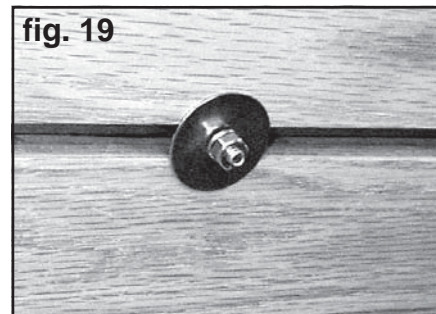

31. Continue installing boards and strips from both sides working toward the center. Do not tighten any bolts completely yet. Leave room for adjustment of boards and strips from side to side.

32. After all gaps between the bed strips and boards are satisfactory, re-check the bed for squareness as in step 5. Tighten all bed strip and angle strip bolts. Be careful when tightening bolts. Do not over-tighten bolts or damage to bed strips or broken bolts may occur.

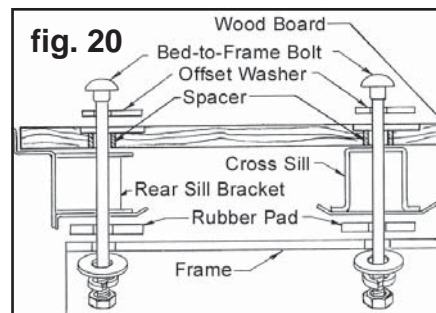

33. Install the completed bed assembly to the truck frame. This will enable you to check the alignment of the bed-to-frame locations.

34. You may wish to use rubber pads between the cross sill locations and the frame. Install the 1/2" diameter coarse thread bed-to-frame carriage bolts and offset washers through the wood boards, cross sills, and the frame. The second set of bed-to-frame bolts from the front may be 10-1/2" bolts due to the frame bracing interference. The other bed-to-frame bolts are 4-1/2" long. Install the 1/2" flat washers, lock washers, and nuts. See figure 20.

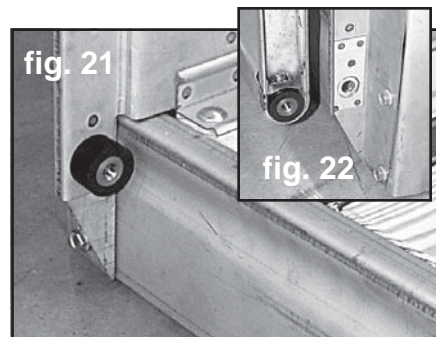

35. Bolt driver side tailgate hinge trunnion to lower rear stake pocket with bolt supplied with trunnion. See figure 21. Place passenger side tailgate hinge trunnion into pivot area on tailgate end. See figure 22. Mount tailgate onto driver side trunnion. Align passenger side trunnion with hole in passenger side stake pocket. Install hinge trunnion bolt.



36. Install tailgate chain eye bolts into stake pockets. This model uses a left and right hand chain assembly. See figure 23.

37. You have assembled the entire bed. Check all parts for correct fit and alignment. Be sure the bolts are in place and that all dimensions are correct. Now remove the bed from the frame and disassemble the parts to prepare for painting.

#### FINAL ASSEMBLY

After the parts are painted, the bed is assembled by the same procedure. By taking the time to assemble and test fit the bed before painting, you have reduced the chances for errors or problems in final assembly.



## FACTS ABOUT OUR PARTS

**Stainless Steel:** Bed strips, angle strips, and stainless mouldings are made of type 430 or 434 bright stainless steel, selected because of its color. It is a magnetic grade of stainless formulated for automotive stainless steel trim. When it is polished and buffed, its bright color looks similar to chrome plating. Stainless hardware items such as bolts, nuts, tailgate chain parts, and bed-to-frame washers are made of nonmagnetic stainless selected for superior resistance to rust and corrosion.

**Care of Stainless / Rusting:** With proper care, stainless steel will remain bright and smooth for long periods of time. It may be cleaned with liquid polish intended for stainless or chrome. DO NOT use steel wool, a steel wire brush, or a buffing wheel which has been used on steel or other metals. Bright stainless parts should be coated with a good nonabrasive wax for maximum protection. Stainless steel will rust or corrode under certain conditions, especially when contaminants such as salt water, battery acid, or steel particles and moisture are present. Frequent washing and waxing are a great protection against damage to stainless steel surfaces.

**Electro-galvanized Steel:** Many of the sheet metal parts MAR-K manufactures are made of electro-galvanized steel. This means the metal is electroplated with a thin layer of zinc by the steel manufacturer. There are several reasons for selecting this steel for our product.

1. Electro-galvanized steel is clean and dry.
2. The zinc protects our parts from rusting during our processing and while on the shelf.
3. After the parts are painted, the zinc under the paint helps prevent loss of paint adhesion or rusting if the paint surface is scratched or damaged.

**Preparing Parts for Painting:** The objectives of painting a part are to protect the metal and to provide a beautiful colored surface. No matter how beautiful the paint, if it doesn't stick to the surface, it will not be satisfactory. Excellent paint adhesion to a metal surface depends mainly on two things, the quality and characteristics of the primer used, and how well the surface is cleaned and prepared for painting. Prepare the surface as follows to help the paint have the best adhesion possible.

### **Steps for Excellent Paint Adhesion on MAR-K parts**

The following steps are a general guideline to obtain excellent paint adhesion to your new parts

1. Select the primer product with the best adhesion properties within the paint system you are using. Products such as PPG "DPLF Epoxy Primer", Sherwin Williams G.B.P. Etching Filler or Etching Primer, and DuPont Variprime 615S/625S Self-Etching Primer will provide excellent adhesion to MAR-K metal parts that have been properly prepared for painting.



2. Wipe the part with solvent such as PPG DX330 Wax and Grease Remover, Sherwin Williams R7K156 Solvent Cleaner, or DuPont 3919S Prep-Sol to remove grease and lubricants from the manufacturing process.
3. Scrub all surfaces of the part with mild detergent in hot water. Rinse well and wipe dry with a clean dry cloth.
4. Wipe the part again with solvent as in step 2 above. The surface must be absolutely clean before sanding to prevent the sanding process from spreading the contaminants or imbedding them into the surface.
5. Scuff sand all areas to be painted using progressively finer grit to about 240 grit paper. Do not try to completely remove or sand through the zinc plating, but the complete part must be thoroughly sanded for best paint adhesion. Use a "DA" sander for broad flat areas and hand sanding for areas that can't be reached with the power sander.
6. Wash and rinse away all sanding residue. Use compressed air to blow the rinse water out of all seams and dry the parts with a clean towel. If the rinse water beads up anywhere on the surface, it is not clean and the solvent wipe and water washing steps must be repeated and additional sanding may be required in that area.
7. Wipe with solvent such as PPG DX330, Sherwin Williams R7K158, or DuPont 3901S to remove any traces of contaminants or sanding residue. Wipe the surface dry with a clean cloth. Do not allow the solvent to evaporate dry on the surface. Wet it again if it should evaporate dry.
8. The parts should be ready for prime painting. PPG recommends a final wipe with a clean damp cloth to remove any residue left from evaporation of the solvent. A quick wipe with a tack rag right before priming helps remove any remaining dust.
9. Immediately after cleaning and drying the parts as above, apply the primer according to the manufacturer's instructions for the products you are using. The recommended drying time between coats is especially important.

**Some other helpful hints for a successful paint job.**

1. Be sure to use fresh paint products that are top quality from a reputable manufacturer. Do not try to economize by using inferior or leftover paint materials.
2. Select all the products for a paint job from a single manufacturer and do not mix different systems within a brand of paint. Use only products that are intended to be used together.
3. Do not use the same air hoses on your paint gun that are also used with air tools such as sanders and air wrenches. Oil in the air tools will find its way into the hose and be a source of contamination for the paint. New hoses contain oils and other contaminants and should be cleaned before use on a paint gun.
4. Wear clean latex or nitrile gloves to prevent fingerprint oils from contaminating the surfaces of your cleaned parts.
5. Plan to prime the parts immediately after cleaning and sanding to prevent any bare steel areas from developing surface rust or the parts from becoming contaminated again.
6. Obtain a technical data sheet for each product being used and read and follow the instructions. The manufacturer's data sheet will provide specific instructions that apply to the product being used. These are available on-line or from your paint supplier.

©Copyright 2007 MAR-K Quality Parts L.L.C. All rights reserved.